

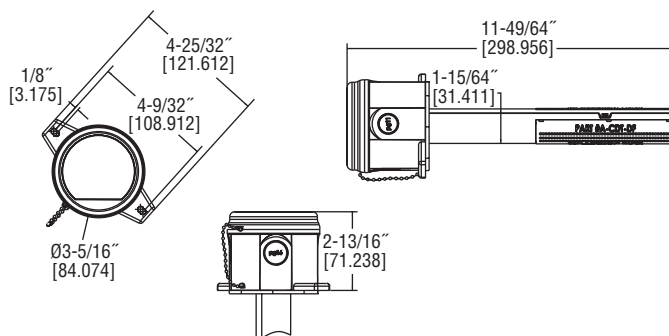

## Series CDT and CDTR Duct Mount Carbon Dioxide/ Temperature/Relative Humidity Transmitter

### Specifications - Installation and Operating Instructions



**Series CDT and CDTR Duct Mount Carbon Dioxide and Temperature Transmitters** accurately monitor the CO<sub>2</sub> concentration and temperature in schools, office buildings, and other indoor environments to help achieve LEED® certification. For increased sensor life, a single-beam dual-wavelength non-dispersive infrared (NDIR) sensor is used to automatically correct the measurement in both occupied and unoccupied buildings against aging effects. The single-beam dual-wavelength sensor technology provides the highest level of accuracy, compared to Automatic Baseline Correction methods, which can unintentionally shift the calibration based on CO<sub>2</sub> levels and barometric pressure conditions. In order to achieve a higher level of accuracy, the Series CDT includes digital barometric pressure adjustment and the ability to field-calibrate the sensor.

Universal outputs allow users to select the transmitter output to be 4 to 20 mA, 0 to 5 VDC or 0 to 10 VDC to work with virtually any building management controller. An optional relay with user adjustable set points can be used to control exhaust fans, open actuated windows or dampers, or signal a light or horn.

For applications that require visual indication, the Series CDT and CDTR can be ordered with the Model A-449 remote LCD display that can plug into the mini-connector port on the internal circuit board. Both the CDT and CDTR can be configured to display temperature only, CO<sub>2</sub> only or CO<sub>2</sub> and temperature together. The CDTR can also display relative humidity or CO<sub>2</sub> and relative humidity together. Menu items that can be accessed include: engineering units, relay output set points, display configuration, transmitter output scaling, ambient barometric pressure and field calibration of the transmitter.

#### Single-beam dual-wavelength sensor advantages:

- Automatically corrects for aging effects in occupied and unoccupied buildings
  - Perfect for hospitals and manufacturing plants that are occupied 24 hours per day
- Measures actual unfiltered light intensity directly
  - Eliminates error from incorrect assumptions of gas concentration in theoretical logic assumption methods

#### SPECIFICATIONS

##### Range:

- CO<sub>2</sub>: 0 to 2000 or 0 to 5000 ppm (depending on model);
- Relative Humidity: 0 to 100%
- Temperature: 32 to 122°F (0 to 50°C).

**Accuracy:** ±40 ppm + 3% of reading (CO<sub>2</sub>); ±2% (RH).

**Thermal Effect:** ±8 ppm / °C at 1100 ppm.

**Non-Linearity:** 16 ppm.

**Barometric Pressure Dependence:** 0.13% of reading per mm of Hg.

**Response Time:** 2 minutes for 99% step change.

**Ambient Operating Temperature:** 32 to 122°F (0 to 50°C).

**Ambient Operating Humidity:** 10 to 95% RH (non-condensing).

**Power Requirements:** 16 to 35 VDC / 19 to 28 VAC.

**Power Consumption:** Average: 2 watts; Peak: 3.75 watts.

**Sensor:** Single-beam, dual-wavelength NDIR.

##### Output:

- Current: 4 to 20 mA (max 500 Ω);
- Voltage: 0 to 5 VDC or 0 to 10 VDC (min 500 Ω);
- Relay: SPST NO 2A @ 30 VDC;
- RTD or thermistor per r-t curves (depending on model).

**Weight:** 5.6 oz (158.8 g).

#### INSTALLATION

**WARNING** Disconnect power supply before installation to prevent electrical shock and equipment damage.

Make sure all connections are in accordance with the job wiring diagram and in accordance with national and local electrical codes. Use copper conductors only.

**CAUTION** Use electrostatic discharge precautions (e.g., use of wrist straps) during installation and wiring to prevent equipment damage.

**CAUTION** Avoid locations where severe shock or vibration, excessive moisture or corrosive fumes are present.

**CAUTION** Do not exceed ratings of this device, permanent damage not covered by warranty may result.

**NOTICE** Upon powering the transmitter, the firmware version will flash on the display. A warm up period of 30 minutes is required for the transmitter to adjust to the current CO<sub>2</sub> concentration.

**NOTICE** Self calibration feature of the transmitter requires exposure to normal outdoor equivalent carbon dioxide level once every thirty days.

LEED® is a registered trademark of the U.S. Green Building Council.

**MOUNTING**

1. Cut hole into duct large enough to insert probe.
2. Attach housing ears to duct using the two self-tapping screws provided.
3. Knock out an opening in the housing and attach an electrical fitting to route electrical wiring. PG11 & PG16 knockouts are molded into the housing.

**WIRING**

Use maximum 18 AWG wire for wiring to terminals. Refer to Figure 5 for wiring information.

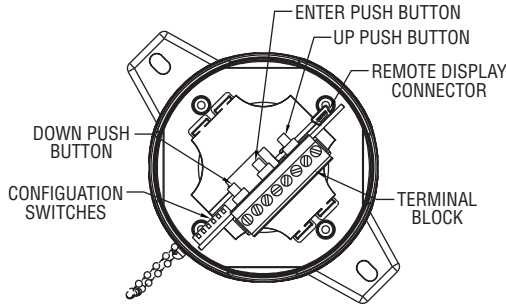

**FIGURE 1: Diagram Of Circuit Board**

**Selection of Current and Voltage Outputs**

Prior to wiring, verify that the current/voltage configuration switches (positions 1 and 2) are set to the desired output type. Refer to Figure 2 to locate the configuration switches. See Figure 3 for diagram of the current/voltage selection switches. For voltage output selection, the output can be 0 to 10 VDC, 0 to 5 VDC, 2 to 10 VDC or 1 to 5 VDC. See Figure 4 for the type of voltage output selection switches (positions 3 & 4).

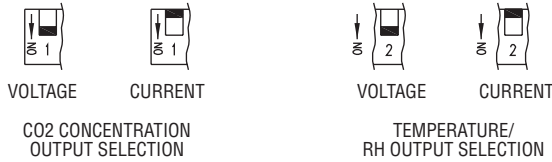

**FIGURE 2: Current/Voltage Output Selection Jumper (PJ1 And PJ2)**

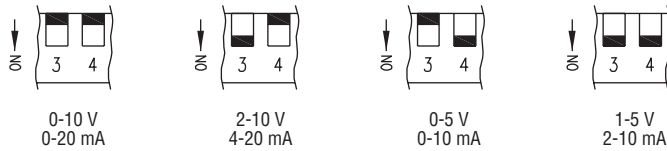
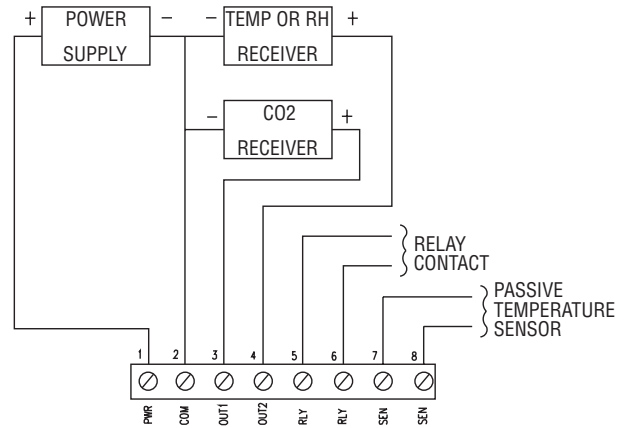

**FIGURE 3: Output Range Selection Jumper**

**Current / Voltage Outputs**

The transmitter may be wired for current or voltage output for both carbon dioxide and temperature. The transmitter can be powered with either 16 to 35 VDC or 19 to 28 VAC. Wire the transmitter according to Figure 5.

**NOTICE** Optional relay can be used as either a dry contact or low voltage switched circuit up to 2 A at 30 VDC.



**FIGURE 4: Active Output Wiring Diagram**

**Thermistor and RTD Outputs**

Thermistor and RTD passive outputs are located on terminals 7 and 8 and do not require any power. Passive temperature outputs are not polarity sensitive.

**Remote Display**

Remote display Model A-449 can be used to display the relative humidity, temperature, and carbon dioxide. The mini USB plug of the remote display plugs into the receptor on the side of the housing. After a short warm up time, the display will begin to show the current temperature and carbon dioxide measurements unless configured by the user to show only temperature or only carbon dioxide.

**ACCESSING MENU PARAMETERS**

- Step 1: To enter the menu structure, press  $\Delta$  and  $\nabla$  simultaneously for 5 seconds (display will show RON parameter).
- Step 2: Press  $\Delta$  or  $\nabla$  to cycle between menu items.
- Step 3: Press  $\square$  to edit the value for the displayed menu item (SET will appear on display).
- Step 4: Press  $\Delta$  or  $\nabla$  to adjust the value of the menu item.
- Step 5: Press  $\square$  to save the changes (SET will disappear).
- Step 6: Repeat Steps 2 through 5 for each of the parameters.
- Step 7: To exit the menu at any time, press and hold  $\Delta$  and  $\nabla$  simultaneously for 5 seconds or wait 10 seconds without pushing any buttons.

## Menu Descriptions

### RON Relay on set point

Sets the CO<sub>2</sub> concentration which the optional relay is energized.

Low limit: 0 PPM  
Factory setting: 1000 PPM  
High limit: 2000/5000 PPM (depending on model)

### ROF Relay off set point

Sets the CO<sub>2</sub> concentration which the optional relay is de-energized. Setting value lower than RON provides direct action for detecting high concentrations of CO<sub>2</sub>. Setting value higher than RON provides indirect action for detecting low concentrations of CO<sub>2</sub>. (△) or (▽) on the LCD display will be lit to indicate when the relay is energized.

Low limit: 0 PPM  
Factory setting: 950 PPM  
High limit: 2000/5000 PPM (depending on model)

### DSP Display configuration

Determines the LCD display configuration during normal operation. The LCD display can indicate the CO<sub>2</sub> concentration, temperature, relative humidity (CDTR only) and CO<sub>2</sub> concentration combined with temperature or relative humidity (CDTR only).

CH CO<sub>2</sub> concentration and relative humidity (CDTR only)  
CT CO<sub>2</sub> concentration and temperature  
C CO<sub>2</sub> concentration only  
T Temperature only  
H Relative humidity only (CDTR only)

### UNI Units selection

Temperature and barometric pressure measurements can be displayed in US engineering units or SI engineering units. The factory default is to display US engineering units.

US units F for temperature and in Hg for barometric pressure  
SI units C for temperature and hPa for barometric pressure

### COL CO<sub>2</sub> low output range

Sets the CO<sub>2</sub> concentration for the lowest output (4 mA or 0 VDC).

Low limit: 0 PPM  
Factory setting: 0 PPM  
High limit: 2000/5000 PPM (depending on model)

### COH CO<sub>2</sub> high output range

Sets the CO<sub>2</sub> concentration for the highest output (20 mA, 5 VDC or 10 VDC). When COH is set above COL, the transmitter is direct acting and the output will increase with an increase in CO<sub>2</sub> level. When COH is below COL, the transmitter is reverse acting and the output will increase with a decrease in CO<sub>2</sub> level.

Low limit: 0 PPM  
Factory setting: 2000/5000 PPM (depending on model)  
High limit: 2000/5000 PPM (depending on model)

### TOL Temperature low output range (CDT with active temperature only)

Sets the temperature for the lowest output (4 mA or 0 VDC).

Low limit: 32.0°F / 0.0°C  
Factory setting: 32.0°F / 0.0°C  
High limit: 122.0°F / 50.0°C

### TOH Temperature high output range (CDT with active temperature only)

Sets the temperature for the highest output (20 mA, 5 VDC or 10 VDC). When TOH is set above TOL, the transmitter is direct acting and the output will increase with an increase in temperature. When TOH is below TOL, the transmitter is reverse acting and the output will increase with a decrease in temperature.

Low limit: 32.0°F / 0.0°C  
Factory setting: 122.0°F / 50.0°C  
High limit: 122.0°F / 50.0°C

### HOL Humidity low output range (CDTR only)

Sets the temperature for the lowest output (4 mA or 0 VDC).

Low limit: 0.0%  
Factory setting: 0.0%  
High limit: 100.0%

### HOH Humidity high output range (CDTR only)

Sets the temperature for the highest output (20 mA, 5 VDC or 10 VDC). When HOH is set above HOL, the transmitter is direct acting and the output will increase with an increase in temperature. When HOH is below HOL, the transmitter is reverse acting and the output will increase with a decrease in temperature.

Low limit: 0.0%  
Factory setting: 100.0%  
High limit: 100.0%

### BAR Barometric pressure



Sets the typical barometric pressure for the location where the transmitter is mounted. The factory setting is for standard pressure at sea level. Adjusting the barometric pressure gives a more accurate measurement, especially at higher elevations. Refer to the elevation charts in Figure 9 for typical barometric pressures at a given elevation.

Low limit: 20.0 in Hg / 600 hPa  
Factory setting: 29.9 in Hg / 1013 hPa  
High limit: 32.0 in Hg / 1100 hPa

### CAL Calibration

Calibrates the carbon dioxide sensor to a known gas value. Read calibration instructions before using this feature. Hold  for 5 seconds.

**CALIBRATING SENSOR**

- Step 1: Slide probe into sealed calibration tube.
- Step 2: Tighten screws to lock probe in place.
- Step 3: Attach gas to the calibration tube.
- Step 4: Follow the steps in the accessing parameter section to access the calibration parameter (CAL).
- Step 5: Press the  button.
- Step 6: Flow zero reference gas at 0.3 SLPM for 5 minutes.
- Step 7: Press and hold the  button for 3 seconds.
- Step 8: Flow the full scale reference gas at 0.3 SLPM for 5 minutes.
- Step 9: Press and hold the  button for 3 seconds.
- Step 10: Exit the parameter menu.
- Step 11: Loosen screws to release probe.
- Step 12: Remove probe from sealed calibration tube.

**MAINTENANCE/REPAIR**

Upon final installation of the Series CDT/CDTR, no routine maintenance is required. The Series CDT/CDTR is not field serviceable and should be returned if repair is needed. Field repair should not be attempted and may void warranty.

**WARRANTY/RETURN**

Refer to "Terms and Conditions of Sales" in our catalog and on our website. Contact customer service to receive a Return Goods Authorization number before shipping the product back for repair. Be sure to include a brief description of the problem plus any additional application notes.

Series	CDT	-2	D	4	4	-LCD	Example: CDT-2W44-LCD
Range		2 5					0 to 2000 ppm CO <sub>2</sub> range 0 to 5000 ppm CO <sub>2</sub> range
Configuration			D				Duct
CO <sub>2</sub> Output				4			4 to 20 mA / 0 to (5 or 10) VDC
Temperature Output					0 4 A B C D E F		None 4 to 20 mA / 0 to (5 or 10) VDC 10 KΩ NTC thermistor type III 10 KΩ NTC thermistor type II 3 KΩ NTC thermistor Pt100 Ω RTD Pt1000 Ω RTD 20 KΩ NTC thermistor
Options						LCD RLY NBC	LCD display Relay No buttons

**FIGURE 5: Model Chart**

Series	CDTR	-2	D	4	4	-LCD	Example: CDT-2W44-LCD
Range		2 5					0 to 2000 ppm CO <sub>2</sub> range 0 to 5000 ppm CO <sub>2</sub> range
Configuration			D				Duct
CO <sub>2</sub> Output				4			4 to 20 mA / 0 to (5 or 10) VDC
Temperature Output					0 A B C D E F		None 10 KΩ NTC thermistor type III 10 KΩ NTC thermistor type II 3 KΩ NTC thermistor Pt100 Ω RTD Pt1000 Ω RTD 20 KΩ NTC thermistor
RH Output						4	4 to 20 mA / 0 to (5 or 10) VDC
Options						LCD RLY NBC	LCD display Relay No buttons

**FIGURE 6: CDTR Model Chart**

US Customary Units		SI Units	
ft	in Hg	m	hPa
0	29.92	0	1013
400	29.50	100	1002
800	29.10	200	990
1200	28.69	300	979
1600	28.29	400	968
2000	27.90	500	957
2400	27.51	600	946
2800	27.13	700	935
3200	26.76	800	924
3600	26.39	900	914
4000	26.02	1000	904
4400	25.66	1100	893
4800	25.30	1200	883
5200	24.95	1300	873
5600	24.60	1400	863
6000	24.26	1500	853
6400	23.93	1600	844
6800	23.60	1700	834
7200	23.27	1800	824
7600	22.94	1900	815
8000	22.63	2000	806
8400	22.31	2100	797
8800	22.00	2200	787
9200	21.70	2300	779
9600	21.40	2400	770
10000	21.40	2500	761

**FIGURE 7: Elevation Chart**

**RESISTANCE VS TEMPERATURE TABLE**

Temperature		Resistance Curves (in Ohms)					
°C	°F	A	B	C	D	E	F
-55	-67.0	607800.00	963849.00	289154.70	78.32	783.2	2394000.00
-50	-58.0	441200.00	670166.00	201049.80	80.31	803.1	1646200.00
-45	-49.0	323600.00	471985.00	141595.50	82.29	822.9	1145800.00
-40	-40.0	239700.00	336479.00	100943.70	84.27	842.7	806800.00
-35	-31.0	179200.00	242681.00	72804.30	86.25	862.5	574400.00
-30	-22.0	135200.00	176974.00	53092.20	88.22	882.2	413400.00
-25	-13.0	102900.00	130421.00	39126.30	90.19	901.9	300400.00
-20	-4.0	78910.00	97081.00	29124.30	92.16	921.6	220600.00
-15	5.0	61020.00	72957.00	21887.10	94.12	941.2	163500.00
-10	14.0	47540.00	55329.00	16598.70	96.09	960.9	122280.00
-5	23.0	37310.00	42327.00	12698.10	98.04	980.4	92240.00
0	32.0	29490.00	32650.00	9795.00	100.00	1000.0	70160.00
5	41.0	23460.00	25392.00	7617.60	101.95	1019.5	53780.00
10	50.0	18780.00	19901.00	5970.30	103.90	1039.0	41560.00
15	59.0	15130.00	15712.00	4713.60	105.85	1058.5	32340.00
20	68.0	12260.00	12493.00	3747.90	107.79	1077.9	25360.00
25	77.0	10000.00	10000.00	3000.00	109.74	1097.4	20000.00
30	86.0	8194.00	8057.00	2417.10	111.67	1116.7	15892.00
35	95.0	6752.00	6531.00	1959.30	113.61	1136.1	12704.00
40	104.0	5592.00	5326.00	1597.80	115.54	1155.4	10216.00
45	113.0	4655.00	4368.00	1310.40	117.47	1174.7	8264.00
50	122.0	3893.00	3602.00	1080.60	119.40	1194.0	6722.00
55	131.0	3271.00	2986.00	895.80	121.32	1213.2	5498.00
60	140.0	2760.00	2488.00	746.40	123.24	1232.4	4520.00
65	149.0	2339.00	2083.00	624.90	125.16	1251.6	3734.00
70	158.0	1990.00	1752.00	525.60	127.08	1270.8	3100.00
75	167.0	1700.00	1480.00	444.00	128.99	1289.9	2586.00
80	176.0	1458.00	1255.00	376.50	130.90	1309.0	2166.00
85	185.0	1255.00	1070.00	321.00	132.80	1328.0	1822.60
90	194.0	1084.00	915.50	274.65	134.71	1347.1	1540.00
95	203.0	939.30	786.60	235.98	136.61	1366.1	1306.40
100	212.0	816.80	678.60	203.58	138.51	1385.1	1112.60
105	221.0	712.60	587.60	176.28	140.40	1404.0	951.00
110	230.0	623.60	510.60	153.18	142.29	1422.9	815.80
115	239.0	547.30	445.30	133.59	144.18	1441.8	702.20
120	248.0	481.80	389.60	116.88	146.07	1460.7	606.40
125	257.0	425.30	341.90	102.57	147.95	1479.5	525.60
130	266.0	376.40	301.00	90.30	149.83	1498.3	N/A
135	275.0	334.00	265.80	79.74	151.71	1517.1	N/A
140	284.0	297.20	235.30	70.59	153.58	1535.8	N/A
145	293.0	265.10	208.90	62.67	155.46	1554.6	N/A
150	302.0	237.00	186.10	55.83	157.33	1573.3	N/A

**FIGURE 8: Resistance vs Temperature**